



IEC 60900

Edition 4.0 2018-06

INTERNATIONAL STANDARD

NORME INTERNATIONALE



**Live working –
Hand tools for use up to 1 000 V AC and 1 500 V DC**

**Travaux sous tension –
Outils à main pour usage jusqu'à 1 000 V en courant alternatif et 1 500 V
en courant continu**

INTERNATIONAL
ELECTROTECHNICAL
COMMISSION

COMMISSION
ELECTROTECHNIQUE
INTERNATIONALE

ICS 13.260; 29.240.20; 29.260.99

ISBN 978-2-8322-5783-8

**Warning! Make sure that you obtained this publication from an authorized distributor.
Attention! Veuillez vous assurer que vous avez obtenu cette publication via un distributeur agréé.**

CONTENTS

FOREWORD.....	5
INTRODUCTION.....	7
1 Scope.....	8
2 Normative references	8
3 Terms and definitions	8
4 Requirements	9
4.1 General requirements	9
4.1.1 Safety.....	9
4.1.2 Performance under load	10
4.1.3 Multiple-ended hand tools.....	10
4.1.4 Marking	10
4.1.5 Separating of covers.....	11
4.1.6 Instructions for correct adjustment and assembly.....	11
4.2 Requirements concerning insulating materials	11
4.2.1 General	11
4.2.2 Thermal stability	12
4.3 Requirement concerning exposed conductive parts of hybrid tools.....	12
4.4 Additional requirements	12
4.4.1 Hand tools capable of being assembled.....	12
4.4.2 Screwdrivers.....	14
4.4.3 Spanners – un-insulated areas	15
4.4.4 Adjustable spanners	16
4.4.5 Pliers, strippers, cable scissors, cable-cutting hand tools	17
4.4.6 Scissors	21
4.4.7 Knives	22
4.4.8 Tweezers.....	23
5 Tests.....	24
5.1 General.....	24
5.2 Visual check	25
5.3 Dimensional check.....	25
5.4 Impact tests	25
5.4.1 Type test	25
5.4.2 Alternative methods in cases where hand tools have completed the production phase	28
5.5 Dielectric tests	28
5.5.1 General requirements	28
5.5.2 Conditioning (for type test only)	29
5.5.3 Dielectric testing of insulated and hybrid hand tools	29
5.5.4 Dielectric testing of insulating hand tools	32
5.6 Indentation test (for <i>insulated hand tools</i>)	33
5.6.1 Type test	33
5.6.2 Alternative methods in cases where insulated hand tools have completed the production phase	34
5.7 Test for adhesion of the insulating material coating of insulated hand tools.....	34
5.7.1 Conditioning	34
5.7.2 Type test	35

5.7.3	Alternative methods in cases where insulated hand tools have completed the production phase	40
5.8	Test of adhesion of exposed conductive parts at the working head of hybrid hand tools	41
5.8.1	Type test	41
5.8.2	Alternative methods in cases where hybrid hand tools have completed the production phase	41
5.9	Mechanical tests	41
5.9.1	Test of adhesion of insulating covers of conductive adjusting or switching elements	41
5.9.2	Insulated hand tools	42
5.9.3	Insulating and hybrid hand tools	42
5.9.4	Tweezers.....	43
5.9.5	Retaining force test for tools capable of being assembled.....	43
5.10	Durability of marking	46
5.11	Flame retardancy test	46
5.11.1	Type test	46
5.11.2	Alternative methods in cases where hand tools have completed the production phase	47
6	Conformity assessment of hand tools having completed the production phase.....	48
7	Modifications	48
Annex A (informative) Description and examples for insulated, hybrid and insulating hand tools.....		49
Annex B (informative) Mechanical strength of insulating and hybrid hand tools		50
B.1	Context.....	50
B.2	General.....	50
B.3	Insulating and hybrid screwdrivers	50
B.4	Insulating and hybrid spanners and ratchets	51
B.5	Insulating and hybrid T-spanners	51
B.6	Insulating and hybrid pliers and cable shears.....	51
Annex C (normative) Suitable for live working; double triangle (IEC 60417-5216:2002-10).....		52
Annex D (informative) Recommendation for use and in-service care		53
D.1	General.....	53
D.2	Storage	53
D.3	Inspection before use.....	53
D.4	Temperature	53
D.5	Periodic examination and electrical retesting	53
Annex E (normative) General type test procedure		54
Annex F (normative) Examples of calculation of the total linear length of insulation and acceptable leakage current (see 5.5.3.1.1).....		55
Annex G (normative) Classification of defects and tests to be allocated		56
Annex H (informative) Rationale for the classification of defects		57
Bibliography.....		59
Figure 1 – Marking of the electrical working limit adjacent to the double triangle symbol (IEC 60417-5216:2002-10).....		11
Figure 2 – Description of the insulating overlapping element and different assembly configurations for hand tools capable of being assembled with square drives		13

Figure 3 – Marking symbol for hand tools capable of being assembled and designed to be interchangeable between different manufacturers (IEC 60417-6168:2012-07)	14
Figure 4 – Illustration of insulation of a typical screwdriver	15
Figure 5 – Illustration of insulation of typical spanners	16
Figure 6 – Insulated or hybrid adjustable spanner	17
Figure 7 – Illustration of insulation of typical pliers	18
Figure 8 – Insulation of pliers	19
Figure 9 – Insulation of multiple slip joint pliers	19
Figure 10 – Insulation of pliers with a functional area below the joint	20
Figure 11 – Illustration of insulation of pliers and nippers for electronics	21
Figure 12 – Insulation of scissors	22
Figure 13 – Insulation of knives	23
Figure 14 – Example of insulation of the handles of tweezers	24
Figure 15 – Example of test arrangement for the impact test – Method A	26
Figure 16 – Example of test arrangement for the impact test – Method B	27
Figure 17 – Dielectric testing arrangement for insulated or hybrid hand tools	30
Figure 18 – Description of dummies for dielectric tests for hand tools capable of being assembled with square drives	31
Figure 19 – Dielectric testing arrangement for insulating hand tools	32
Figure 20 – Indentation test	34
Figure 21 – Principle of the testing device for checking adhesion of the insulating coating on conductive parts of the insulated hand tool – Test on the working head – Method A	36
Figure 22 – Principle of the testing device for checking adhesion of the insulating coating on conductive parts of the insulated hand tools – Test on the working head – Method B	37
Figure 23 – Testing device for checking adhesion of the insulating coating of insulated screwdrivers on conductive parts and the handle	38
Figure 24 – Example of mountings for checking stability of adhesion of the insulation of the entire insulated hand tool	40
Figure 25 – Dummies for testing locking systems used with square drives of nominal size 12,5 mm of ISO 1174	44
Figure 26 – Dummies for testing locking systems used with square drives of nominal size 10 mm of ISO 1174	45
Figure 27 – Example of a flame retardancy test arrangement	47
Table 1 – Dimensions and tolerances of the insulating overlapping element	13
Table 2 – Dimensions and tolerances for dummies to be used for dielectric tests	31
Table B.1 – Torque values for insulating and hybrid screwdrivers	50
Table E.1 – Sequential order for performing type tests	54
Table G.1 – Classification of defects and associated requirements and tests	56
Table H.1 – Justification for the type of defect	57

INTERNATIONAL ELECTROTECHNICAL COMMISSION

**LIVE WORKING – HAND TOOLS FOR USE UP
TO 1 000 V AC AND 1 500 V DC****FOREWORD**

- 1) The International Electrotechnical Commission (IEC) is a worldwide organization for standardization comprising all national electrotechnical committees (IEC National Committees). The object of IEC is to promote international co-operation on all questions concerning standardization in the electrical and electronic fields. To this end and in addition to other activities, IEC publishes International Standards, Technical Specifications, Technical Reports, Publicly Available Specifications (PAS) and Guides (hereafter referred to as "IEC Publication(s)"). Their preparation is entrusted to technical committees; any IEC National Committee interested in the subject dealt with may participate in this preparatory work. International, governmental and non-governmental organizations liaising with the IEC also participate in this preparation. IEC collaborates closely with the International Organization for Standardization (ISO) in accordance with conditions determined by agreement between the two organizations.
- 2) The formal decisions or agreements of IEC on technical matters express, as nearly as possible, an international consensus of opinion on the relevant subjects since each technical committee has representation from all interested IEC National Committees.
- 3) IEC Publications have the form of recommendations for international use and are accepted by IEC National Committees in that sense. While all reasonable efforts are made to ensure that the technical content of IEC Publications is accurate, IEC cannot be held responsible for the way in which they are used or for any misinterpretation by any end user.
- 4) In order to promote international uniformity, IEC National Committees undertake to apply IEC Publications transparently to the maximum extent possible in their national and regional publications. Any divergence between any IEC Publication and the corresponding national or regional publication shall be clearly indicated in the latter.
- 5) IEC itself does not provide any attestation of conformity. Independent certification bodies provide conformity assessment services and, in some areas, access to IEC marks of conformity. IEC is not responsible for any services carried out by independent certification bodies.
- 6) All users should ensure that they have the latest edition of this publication.
- 7) No liability shall attach to IEC or its directors, employees, servants or agents including individual experts and members of its technical committees and IEC National Committees for any personal injury, property damage or other damage of any nature whatsoever, whether direct or indirect, or for costs (including legal fees) and expenses arising out of the publication, use of, or reliance upon, this IEC Publication or any other IEC Publications.
- 8) Attention is drawn to the Normative references cited in this publication. Use of the referenced publications is indispensable for the correct application of this publication.
- 9) Attention is drawn to the possibility that some of the elements of this IEC Publication may be the subject of patent rights. IEC shall not be held responsible for identifying any or all such patent rights.

International Standard IEC 60900 has been prepared by IEC technical committee 78: Live working.

This fourth edition cancels and replaces the third edition, published in 2012. This edition constitutes a technical revision.

This edition includes the following significant technical changes with respect to the previous edition:

- a) addition of a third category of tools has been added, namely *hybrid hand tools*;
- b) introduction of a new informative Annex A on examples of *insulated, insulating and hybrid hand tools*.

The text of this standard is based on the following documents:

FDIS	Report on voting
78/1221/FDIS	78/1229/RVD

Full information on the voting for the approval of this International Standard can be found in the report on voting indicated in the above table.

This document has been drafted in accordance with the ISO/IEC Directives, Part 2.

Terms defined in Clause 3 are given in *italic* print throughout this document.

The committee has decided that the contents of this document will remain unchanged until the stability date indicated on the IEC website under "<http://webstore.iec.ch>" in the data related to the specific document. At this date, the document will be

- reconfirmed,
- withdrawn,
- replaced by a revised edition, or
- amended.

IMPORTANT – The 'colour inside' logo on the cover page of this publication indicates that it contains colours which are considered to be useful for the correct understanding of its contents. Users should therefore print this document using a colour printer.

INTRODUCTION

This document has been prepared in accordance with the requirements of IEC 61477 where applicable.

The products covered by this document may have an impact on the environment during some or all stages of its life cycle. These impacts can range from slight to significant, be of short-term or long-term duration, and occur at the global, regional or local level.

This document does not include requirements and test provisions for the manufacturers of the products, or recommendations to the users of the products for environmental improvement. However, all parties intervening in their design, manufacture, packaging, distribution, use, maintenance, repair, reuse, recovery and disposal are invited to take account of environmental considerations.

LIVE WORKING – HAND TOOLS FOR USE UP TO 1 000 V AC AND 1 500 V DC

1 Scope

This document is applicable to *insulated, insulating and hybrid hand tools* used for working live or close to live parts at nominal voltages up to 1 000 V AC and 1 500 V DC.

The products designed and manufactured according to this document contribute to the safety of the users provided they are used by skilled persons, in accordance with safe methods of work and the instructions for use (where appropriate).

2 Normative references

The following documents are referred to in the text in such a way that some or all of their content constitutes requirements of this document. For dated references, only the edition cited applies. For undated references, the latest edition of the referenced document (including any amendments) applies.

IEC 60060-1, *High-voltage test techniques – Part 1: General definitions and test requirements*

IEC 60212, *Standard conditions for use prior to and during the testing of solid electrical insulating materials*

IEC 60417, *Graphical symbols for use on equipment* (available at: <http://www.graphical-symbols.info/equipment>)

IEC 61318, *Live working – Conformity assessment applicable to tools, devices and equipment*

IEC 61477, *Live working – Minimum requirements for the utilization of tools, devices and equipment*

ISO 1174-1, *Assembly tools for screw and nuts – Driving squares – Part 1: Driving squares for hand socket tools*

ISO 9654, *Pliers and nippers for electronics – Single-purpose nippers – Cutting nippers*

ISO 9655, *Pliers and nippers for electronics – Single-purpose pliers – Pliers for gripping and manipulating*

ISO 9656, *Pliers and nippers for electronics – Test methods*

ISO 9657, *Pliers and nippers for electronics – General technical requirements*

3 Terms and definitions

For the purposes of this document, the terms and definitions given in IEC 61318 and the following apply.

ISO and IEC maintain terminological databases for use in standardization at the following addresses:

- IEC Electropedia: available at <http://www.electropedia.org/>
- ISO Online browsing platform: available at <http://www.iso.org/obp>

NOTE The definitions of general terms used in this document are given in IEC 60050 or in special definitions given in IEC 60743.

3.1

hand tool

hand held tool

Note 1 to entry: *Hand tools* may be *insulated hand tools*, *insulating hand tools* or *hybrid hand tools* (see Annex A).

Note 2 to entry: *Hand tools* are normally tools such as screwdrivers, pliers, spanners or knives.

Note 3 to entry: *Hand tools* are designed to provide protection to the worker against electric shock.

[SOURCE: IEC 60050-651:2014, 651-21-19, modified – Note 1 to entry has been modified to refer to Annex A.]

3.1.1

hybrid hand tool

hand tool made from insulating material(s) with exposed conductive parts at the *working head*

Note 1 to entry: *Hybrid hand tools* may have some non-exposed conductive parts used for reinforcement.

[SOURCE: IEC 60050-651:2014, 651-21-22]

3.1.2

insulated hand tool

hand tool made of conductive material(s), fully or partially covered by insulating material(s)

[SOURCE: IEC 60050-651:2014, 651-21-20]

3.1.3

insulating hand tool

hand tool made totally or essentially from insulating material(s) except for inserts made from conductive material(s) used for reinforcement, but with no exposed conductive parts

[SOURCE: IEC 60050-651: 2014, 651-21-21,]

3.2

working head

part of the tool head that is limited to the working surface and the contact area

Note 1 to entry: See Figures 5 and 7.

4 Requirements

4.1 General requirements

4.1.1 Safety

Insulated, *insulating* and *hybrid hand tools* shall be manufactured and dimensioned in such a way that they protect the user from electric shock.

NOTE 1 *Insulating hand tools* minimize the risk of short-circuits between two parts at different potentials.

NOTE 2 *Hybrid hand tools* reduce the risk of short-circuits between two parts at different potentials.

NOTE 3 *Insulated hand tools*, completely covered by insulating material, except the conductive part of the working surface, reduce the risk of short-circuits between two parts at different potentials.

The following requirements have been prepared in order that the *hand tools* covered by this document are designed and manufactured to contribute to the safety of the users, provided they are used by persons skilled for live working, in accordance with safe methods of work and the instructions for use (where appropriate).

4.1.2 Performance under load

The mechanical specifications for *insulated hand tools* shall comply with the corresponding ISO standards, or, where no ISO standard exists, with a standard specified by the manufacturer or the customer (for example a national standard). The mechanical specifications for the working parts of the *hand tools* shall be retained even after application of an insulating layer.

Insulating and hybrid hand tools specially designed for live working may have lower stress resistance than *insulated hand tools*, but they shall withstand the expected workloads without failing due to remaining deformation or breaking. These *hand tools* can be equipped with devices that limit the workloads that can be applied with them, for example by overload slipping clutches (see also Annex B).

4.1.3 Multiple-ended hand tools

Multiple-ended *hand tools*, such as box spanner, keys for hexagonal socket screws, double-ended socket-spanner, double-head open-end spanner, etc., are not allowed for *insulated hand tools* but are allowed for *insulating or hybrid hand tools* if the design assures that there is no conductive connection between two of the *working heads*.

4.1.4 Marking

The marking shall be clearly identifiable by persons with normal or corrected sight without further magnification.

Each *hand tool* and/or tool component shall be legibly and permanently marked with the following items of marking:

- on the insulating material or on the metal part:
 - marking of the origin (manufacturer's name or trade mark);
- on the insulating material:
 - model/type reference;
 - year of manufacture (at least the last two digits of the year);
 - symbol IEC 60417-5216:2002-10 – Suitable for live working; double triangle (see Annex C);
NOTE For the symbol, the exact ratio of the height of the figure to the base of the triangle is 1,43:1. For the purpose of convenience, this ratio can be between the values of 1,4 and 1,5.
 - indication 1 000 V (i.e. the electrical working limit for alternating current), immediately adjacent to the double triangle symbol (see Figure 1 for an example);



IEC

Figure 1 – Marking of the electrical working limit adjacent to the double triangle symbol (IEC 60417-5216:2002-10)

- number of the relevant IEC standard immediately adjacent to the double triangle symbol (IEC 60900);
- for *hand tools* designed for use at extremely low temperature: letter “C” (see 4.2.2);
- additional marking for *hand tools* capable of being assembled and designed to be interchangeable between different manufacturers (see 4.4.1.3.2);
- additional marking where specified by the customer (for example ownership mark).

The *hand tools* shall bear no voltage marking apart from those described above.

NOTE For example, the indication of test voltage may lead to the assumption that the *hand tool* is suitable for work at that voltage.

Other characteristics or information not needed at the work location, like the year of publication of the standard and the type of *hand tool*, shall be associated to the product item by other means, such as coded information (bar codes, microchips, etc.), or shall be associated to its packaging.

The double triangle symbol shall be at least 3 mm high; the letter and the figures of the electrical working limit shall be at least 2 mm high (see Figure 1).

4.1.5 Separating of covers

If *hand tools* have conductive elements (for example: torque adjusting screws, operating direction switches, etc.) which are insulated with covers of insulating materials, these covers shall be securely fastened, so that they do not become separated during normal use (see 5.9.1).

4.1.6 Instructions for correct adjustment and assembly

Where the manufacturer deems that instructions are necessary for correct adjustment or assembly, then the manufacturer shall provide these in accordance with the general provisions given in IEC 61477 (see also Annex D).

4.2 Requirements concerning insulating materials

4.2.1 General

The insulating material shall be selected according to the electrical, mechanical and thermal stresses to which it may be exposed during use. In addition, the insulating material shall have an adequate resistance to ageing and be flame retardant.

The insulating coating may consist of one or more layers. If two or more layers are adopted, contrasting colours may be used.

The design and construction of the handles shall provide a secure handhold and prevent unintentional hand slipping. The handle and guard dimensions given in different figures are applicable to all types of *hand tools* in order to define the handling zone.

4.2.2 Thermal stability

The service ability of the *hand tools* shall not be impaired within the temperature range -20 °C to $+70\text{ °C}$.

The insulating material applied on *hand tools* shall adhere securely to the conductive part from -20 °C to $+70\text{ °C}$.

Hand tools intended for use at extremely low temperatures (down to -40 °C) shall be designated "Category °C" and shall be designed for this purpose.

4.3 Requirement concerning exposed conductive parts of hybrid tools

Exposed conductive parts shall be securely fastened, so that they do not become separated during normal use (see 5.8).

4.4 Additional requirements

4.4.1 Hand tools capable of being assembled

4.4.1.1 Retaining devices for hand tools capable of being assembled

Hand tools capable of being assembled shall have suitable retaining devices to prevent unintentional separation of the assembly. The retaining forces shall be tested according to 5.9.5.

4.4.1.2 Insulation design for hand tools capable of being assembled

In the case of connecting parts of *hand tools* capable of being assembled, the insulation shall be applied in such a manner that if any part becomes detached during use by exceeding the retaining forces according to 5.9.5, no conductive part, which may still be live, can be inadvertently touched or cause a disruptive discharge.

4.4.1.3 Hand tools capable of being assembled with square drives

4.4.1.3.1 General

Hand tools capable of being assembled with square drives shall have square drives and square sockets in accordance with ISO 1174-1 (for separating forces, see 5.9.5.2). To ensure compatibility of insulation between different manufacturers, these *hand tools* shall be designed with overlapping elements described in Figure 2. Their dimensions and tolerances shall be in accordance with Table 1.

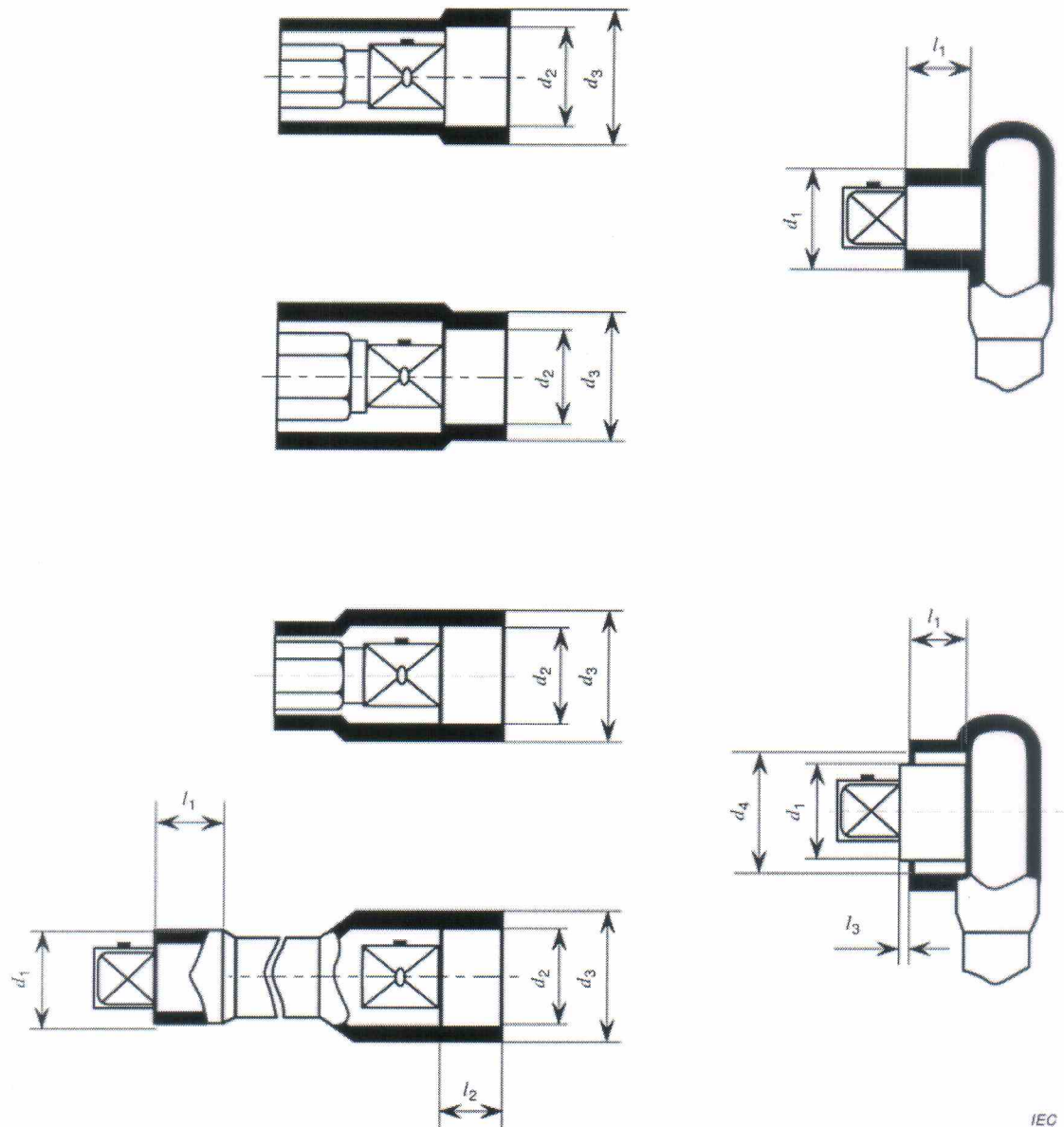

IEC

Figure 2 – Description of the insulating overlapping element and different assembly configurations for hand tools capable of being assembled with square drives

Table 1 – Dimensions and tolerances of the insulating overlapping element

Dimensions in millimetres

Nominal size of the square drive	l_1 min.	l_2 $\begin{smallmatrix} +2 \\ 0 \end{smallmatrix}$	l_3 $\begin{smallmatrix} +0,5 \\ -0,5 \end{smallmatrix}$	d_1 $\begin{smallmatrix} 0 \\ -1,5 \end{smallmatrix}$	d_2 $\begin{smallmatrix} +15 \\ 0 \end{smallmatrix}$	d_3 $\begin{smallmatrix} 0 \\ -1,5 \end{smallmatrix}$	d_4 $\begin{smallmatrix} +1,5 \\ 0 \end{smallmatrix}$
6,3	19	16	2	12,5	13	18	19
10	19	16	2	17,5	18	23	24
12,5	19	16	2	21,5	22	27	28
20	19	16	2	32	33	38	39

$l_1, l_2, l_3, d_1, d_2, d_3$ and d_4 are described in Figure 2.

4.4.1.3.2 Interchangeability of components made by different manufacturers

Hand tools capable of being assembled and designed to be interchangeable between different manufacturers shall be specifically marked as such.

The marking symbol and the dimensions are given in Figure 3. The dimension H shall be greater than or equal to 5 mm.

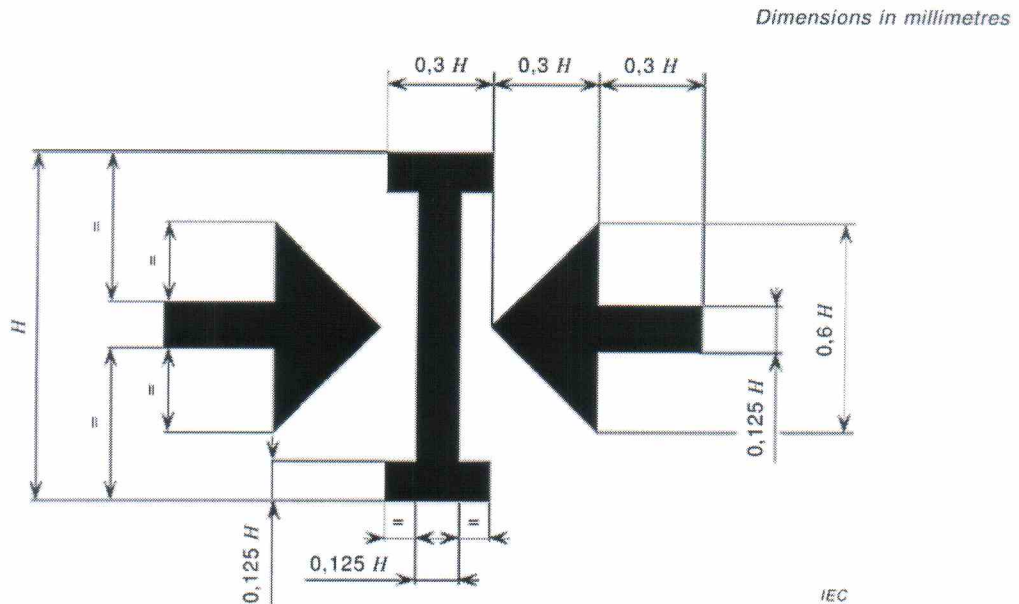

Figure 3 – Marking symbol for hand tools capable of being assembled and designed to be interchangeable between different manufacturers (IEC 60417-6168:2012-07)

The reliable function of locking systems used for these *hand tools* shall be tested by applying a separation test in accordance with 5.9.5 with a corresponding dummy.

For this kind of *hand tools*, instructions for correct assembly are mandatory. The manufacturer shall include the following information: “To assure that the complete assembly of *insulated hand tool* components from different manufacturers will withstand separating forces that are expected during the intended use, prior to the use of any assembly the user shall assure, by pulling by hand in a separating direction, that the retaining devices of all used elements are working efficiently”.

4.4.2 Screwdrivers

4.4.2.1 Un-insulated areas

For insulated or hybrid screwdrivers, an un-insulated conductive area having a maximum length of 18 mm is permissible on the *working head* (see Figure 4).

Dimensions in millimetres

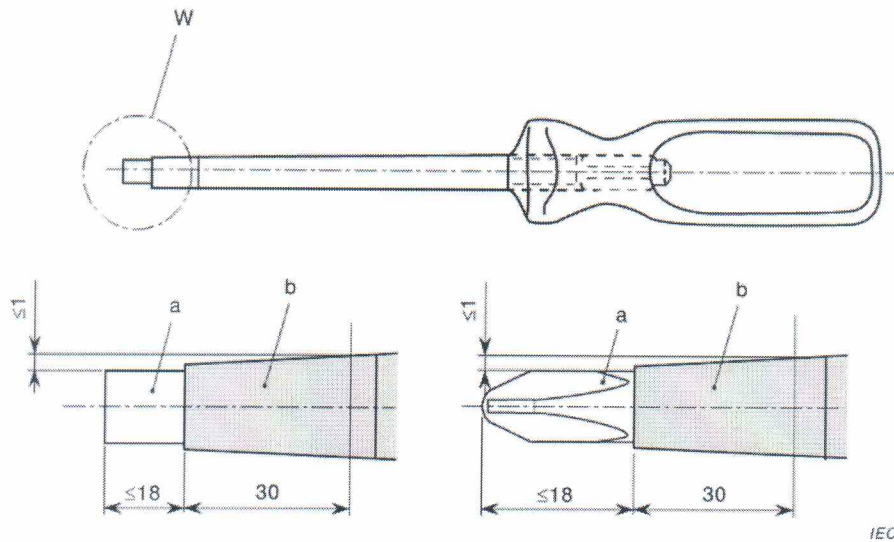
**Key**

a conductive part

b insulation

W *working head***Figure 4 – Illustration of insulation of a typical screwdriver****4.4.2.2 Shape of shaft insulation**

The shaft insulation of insulated screwdrivers shall be bonded to the handle.

The outer diameter of the insulation of insulated and hybrid screwdrivers, over a length of 30 mm, in area "W" of Figure 4, shall not exceed by more than 2 mm the width of the shaft at the tip or the width of the tip, whatever is the larger dimension. This area may be parallel or tapered towards the tip.

This requirement does not apply to insulated bit sockets (or insulated socket drivers).

4.4.2.3 Screwdrivers with exchangeable working heads

Insulated or hybrid screwdrivers with exchangeable *working heads* are regarded as *hand tools* capable of being assembled. They shall meet the relevant requirements. The outer diameter of the insulation may exceed the dimensions of 4.4.2.2.

4.4.2.4 Screwdrivers with screw retaining devices

If an insulated or hybrid screwdriver has a screw retaining device, the screwdriver itself shall meet the requirements of this document. The outer diameter of the retaining device may exceed the dimensions of 4.4.2.2. The retaining device shall be made from insulating material.

4.4.3 Spanners – un-insulated areas

The following un-insulated areas on the *working head* of insulated and hybrid spanners are permissible (see Figure 5):

- single headed spanner: the working surface;

NOTE At the request of the customer, the un-insulated area can be extended to the *working head*.

- ring spanner, socket-spanner, T spanner: the working surface and the contact area.

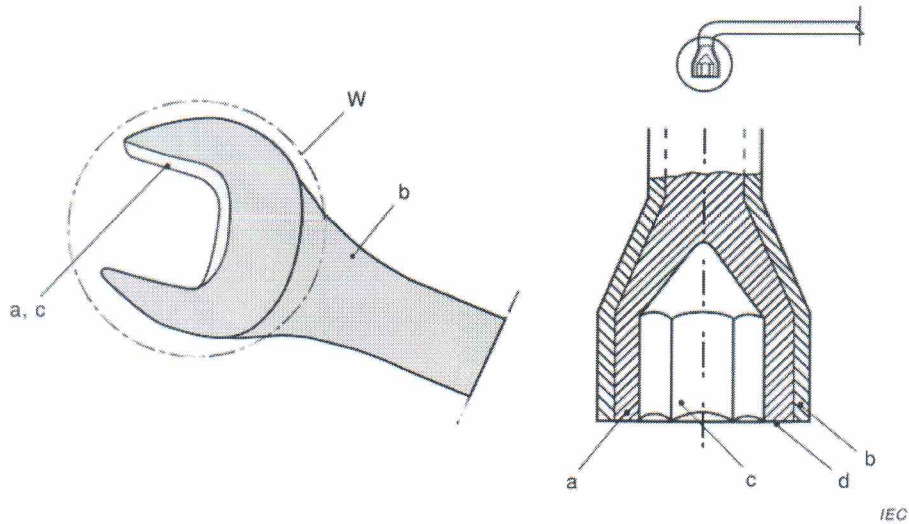

Key

- a conductive part
- b insulation
- c working surface
- d contact area
- W *working head*

Figure 5 – Illustration of insulation of typical spanners

4.4.4 Adjustable spanners

The insulation of insulated adjustable spanners shall be applied as far as possible towards the *working head*. The un-insulated area may be extended to the *working head*. If the *working head* remains un-insulated, a guard shall be applied so that the hand is prevented from slipping towards the uncovered conductive parts of the head. For the minimum dimensions of the guards, see Figure 6.

In the case of hybrid adjustable spanners where there are more uncovered conductive parts than the working surface at the head, a guard shall be applied.

Dimensions in millimetres

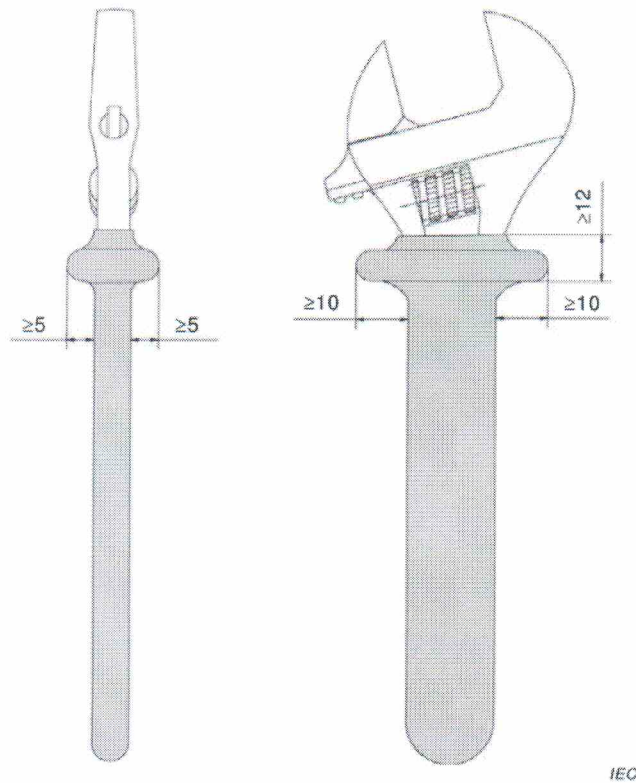
**Figure 6 – Insulated or hybrid adjustable spanner**

4.4.5 Pliers, strippers, cable scissors, cable-cutting hand tools

The handle insulation of such *insulated* or *hybrid hand tools* shall have a guard so that the hand is prevented from slipping towards the uncovered conductive parts of the head (see Figure 7 as an example).

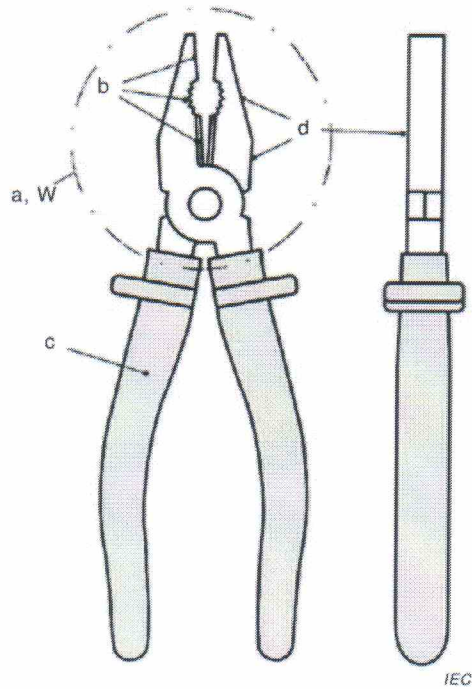

Key

- a conductive part
- b working surface
- c insulation
- d contact area
- W *working head*

Figure 7 – Illustration of insulation of typical pliers

The height of the guard shall be sufficient to prevent the slipping of the fingers towards the uncovered conductive parts during the work.

For pliers, the minimum dimensions of the guard shall be (see Figures 8, 9 and 10 as an example):

- 10 mm on the left and on the right of the pliers held on a flat surface;
- 5 mm on the upper and lower part of the pliers held on a flat surface.

The minimum insulated distance between the inner edge of each guard and any non-insulated parts shall be 12 mm (see Figures 8, 9, 10 and 11). The insulation portion in front of the guard shall extend as far as possible towards the *working head*.

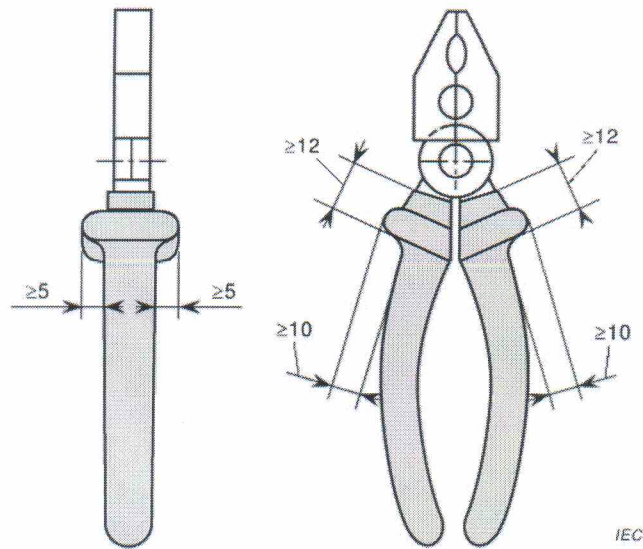
Dimensions in millimetres**Figure 8 – Insulation of pliers**

In the case of a slip joint, a guard of 5 mm shall be provided for the inner part of the handles. Refer to Figure 9 for further dimensioning.

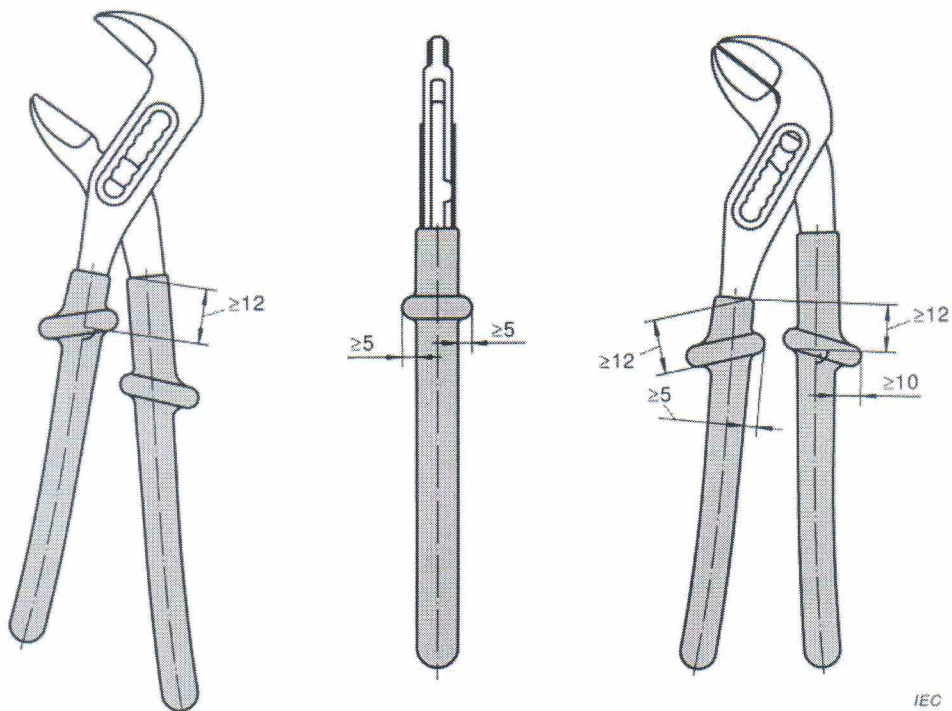
Dimensions in millimetres**Figure 9 – Insulation of multiple slip joint pliers**

Where there is a functional surface below the joint, an inner guard shall be provided (as used with multiple slip joint pliers). See Figure 10.

Dimensions in millimetres

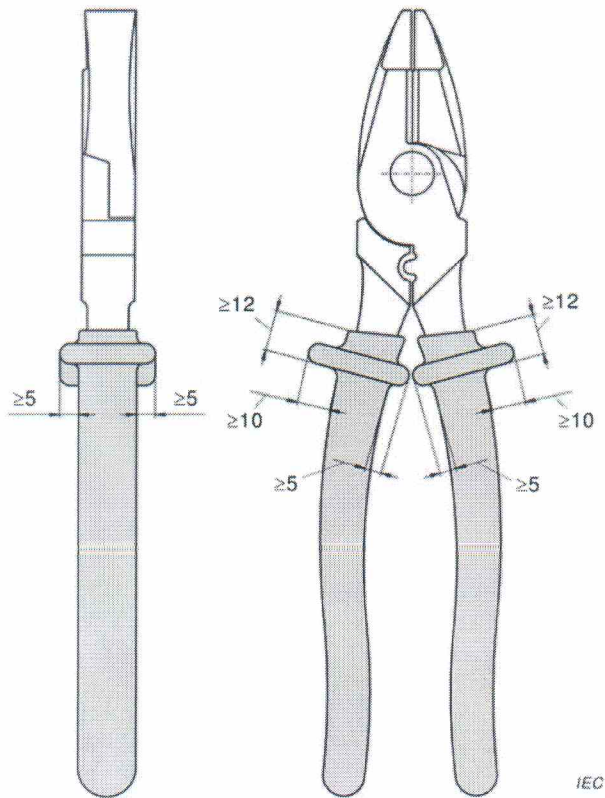

Figure 10 – Insulation of pliers with a functional area below the joint

Where the handles of the *hand tools* are longer than 400 mm, a guard is not required.

In the case of insulated pliers and nippers for electronics, the dimensions of the guard shall be at least:

- 5 mm on left and right of the pliers held on a flat surface;
- 3 mm on the upper part and the lower part of the pliers held on a flat surface.

The minimum insulated distance between the inner edge of the guard and the non-insulated part shall be 12 mm. The insulation portion in front of the guard shall extend as far as possible towards the *working head* (see Figure 11).

Insulated pliers and nippers for electronics shall be in accordance with ISO 9656 and ISO 9657 and, where relevant, with ISO 9654 or ISO 9655

Dimensions in millimetres

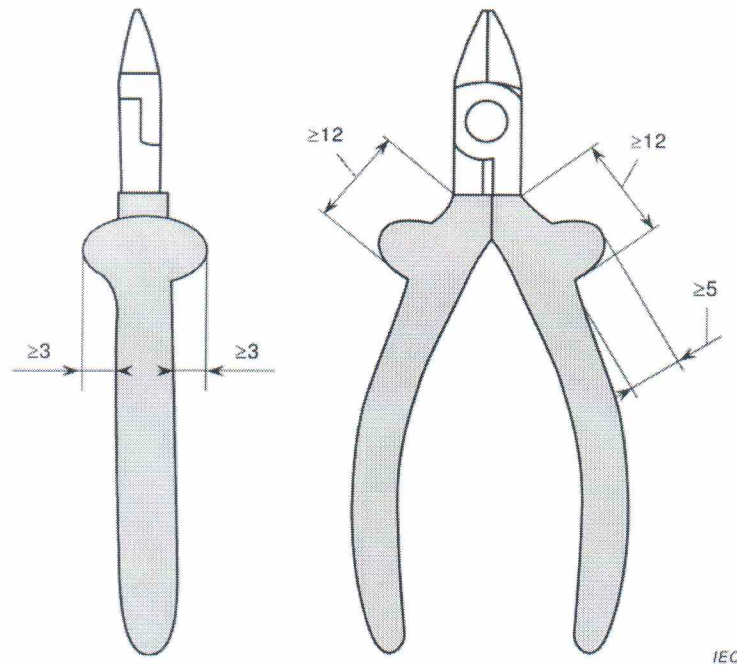

Figure 11 – Illustration of insulation of pliers and nippers for electronics

4.4.6 Scissors

A typical insulation of insulated scissors is shown in Figure 12.

The shackles of the scissors shall have the design presented in Figure 12a or the design presented in Figure 12b.

The maximum length of the un-insulated parts of scissors shall not exceed 100 mm.

The insulation portion in front of the guard shall extend as far as possible towards the *working head*. If the insulated length in front of the shackle is less than 50 mm, at least one guard is required.

Dimensions in millimetres

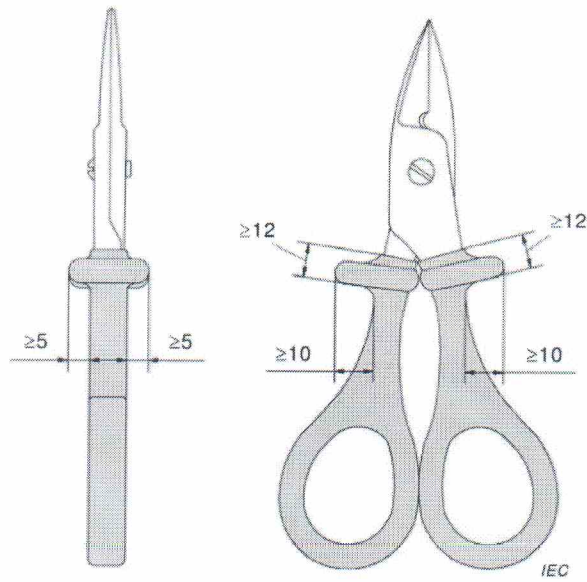

Figure 12a

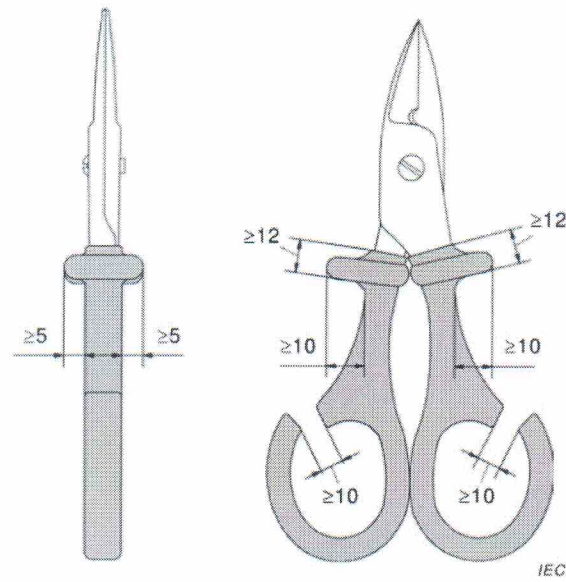

Figure 12b

Figure 12 – Insulation of scissors

4.4.7 Knives

Figure 13 shows an example for the application of the insulation of insulated or hybrid knives. The dimensions of insulated or hybrid knives shall be in accordance with Figure 13.

Dimensions in millimetres

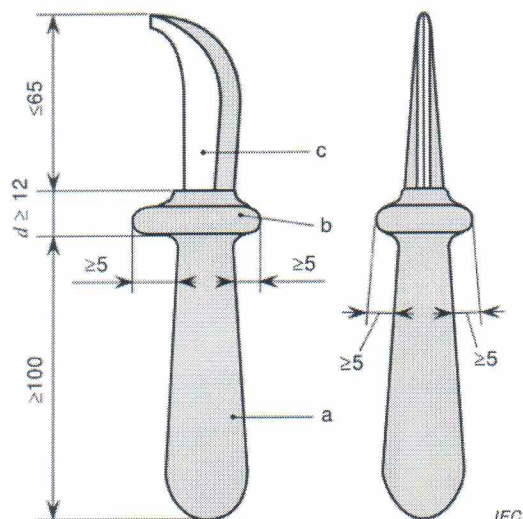
**Key**

- a insulation
- b guard
- c cutting blade (not insulated)
- d distance between the inner edge of the guard and the non-insulated part

Figure 13 – Insulation of knives**4.4.8 Tweezers**

The total length l of tweezers shall be 130 mm minimum and 200 mm maximum. The length of the handles g shall be 80 mm minimum (see Figure 14).

Both handles of the tweezers shall have a guard towards the *working head*. The guard shall not be movable. Its height h and width b shall be sufficient (5 mm minimum) to prevent any slipping of the fingers during the work towards the un-insulated length u of the *working head*. On both handles, the insulated or insulating length e between the guard and the *working head* shall be 12 mm minimum and 35 mm maximum (see Figure 14).

The un-insulated length u of the *working head* shall not exceed 20 mm (see Figure 14).

In the case of tweezers with a metallic *working head*, the metallic part shall have a minimum hardness of 35 HRC at least from the *working head* up to the handles.